

Press Release

AC/DC power supply for DIN mounting rails and wall mounting

The synchronised AC/DC power supplies of the ZAT series manufactured by Zentro-Elektrik can be used as power supply units or as battery chargers. The robust reliable devices have been designed for use in telecommunications and industry. They are available in the output classes of 60 W, 120 W and 240 W and the output voltages of 12 VDC, 24 VDC, 36 VDC, 48 VDC with a wide adjustment range from +25 ... -15%. Thus, many applications are conceivable, for example as battery back-up system with temperature-compensated charging and undervoltage shut-down. In addition, several monitoring and alarm functions are available as well as the possibility of a battery test. The devices can be operated with output decoupling diode mounted, switched in parallel and in series, in a temperature range of between -40 ... +70° Celsius and type-related efficiency of between 82 ... 90 per cent.



Additional data is available from:
ZENTRO-ELEKTRIK GmbH KG

Serie ZAT primär getaktet für Trageschienenmontage

Stromversorgung und Batterielader für Industrie- und Telekom-Anwendung
Ausgangsleistung 60W, 120W, 250W
temperaturgeführte Ladespannung



Eingang:
Eingangswchelsspannung 60W 90-264V 45-65Hz
120W 230/115V 45-65Hz
250W 230/115V 45-65Hz

Ausgang:
Ausgangsgleichspannung 12V...48V
Ausgangsleistung siehe Tabelle
Netzausfallüberbrückung 60W > 50ms
120W > 20ms
250W > 20ms
Wirkungsgrad 82% - 90%

Regeldaten:
Netzausregelung < 0,15%
U_{in} min...U_{in} max
Lastausregelung ohne Entk.-diode < 0,5% - 1,0%

Betriebsgrößen:
Betriebstemperaturbereich -40°C - +70°C
Leistungsreduzierung ab + 55°C
12V 250W ab + 45°C
Kühlung Konvektion

Sicherheit:
Elektrische Sicherheit EN60950-1 class 1, UL508
Prüfspannung prim. - sek.: 3,00 kV_{eff}
prim. - Masse: 1,5 kV_{eff}
sek. - Masse: 500V DC

Abmessungen:

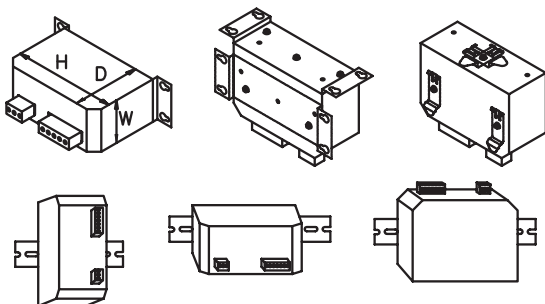

	60W	125W	250W
Breite (W)	51 mm	66 mm	75 mm
Höhe (H)	121 mm	148 mm	173 mm
Tiefe (D)	81 mm	113 mm	122 mm

EMV:
Störaussendung EN61000-6-3
Störfestigkeit EN61000-6-2

Steuer-, Bedien- und Anzeigeelemente:
Betriebsanzeige LED, grün
Einstellung Spannung mit: Potentiometer
Melderelais siehe Standard features/Option

Elektrische Anschlüsse 2,5mm² Schraubklemme

Mechanik und Gewicht:
Abmessungen 60W 51x121x81mm (BxHxT)
120W 66x148x113mm (BxHxT)
250W 75x173x122mm (BxHxT)
Gewicht 60W 360g
120W 840g
250W 1,5kg

Gehäuse IP20, Stahl/Aluminium

Montage:
Befestigung DIN Schiene TS35

Leistungsreduzierung

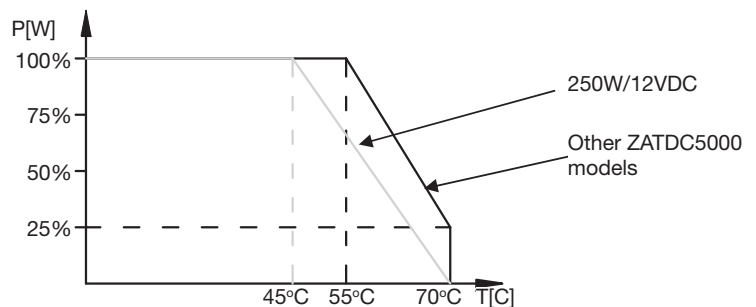

Bestellbezeichnung:

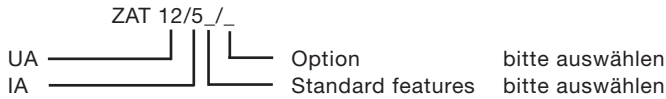

Standard features:

- 60W 1 Melderelais
- 3 Melderelais und Entkoppeldiode
- 120/250W 1 Melderelais und OVP
- 3 Melderelais und Entkoppeldiode und OVP

Option:

- 60W 0 shut down
- 2 shut down und OVP
- 120/250W 0 Melderelais und shut down
- 2 Entkoppeldiode, Melderelais, shut down
- 4 output remote control for battery test, Melderelais, OVO, Entkoppeldiode

Typ	UA / IA	Watt	Eingangsspannung		
Stromversorgung			230/115VAC	90..264VAC	PFC
ZAT 12/5/_/_	12V5A	60		X	
ZAT 24/2,5/_/_	24V2,5A	60		X	
ZAT 36/1,7/_/_	36V1,7A	60		X	
ZAT 48/1,25/_/_	48V1,7A	60		X	
ZAT 12/10/_/_	12V10A	120	X		
ZAT 24/5/_/_	24V5A	120	X		
ZAT 48/2,5/_/_	48V2,5A	120	X		
ZAT 12V18/_/_	12V18A	240	X		X
ZAT 24/10/_/_	24V10A	240	X		X
ZAT 48/5/_/_	48V5A	240	X		X
Batterie-Lader					
ZAT 13,7/4,4/_/_	13,7V4,4A	60		X	
ZAT 27,4/2,2/_/_	27,4V2,2A	60		X	
ZAT 41, 1/1,5/_/_	41,1V1,5A	60		X	
ZAT 54,8/1,1/_/_	54,8V1,1A	60		X	
ZAT 13,7/10/_/_	13,7V10A	137	X		
ZAT 27,4/5/_/_	27,4V5A	137	X		
ZAT 54,8/2,5/_/_	54,8V2,5	137	X		
ZAT 13,7/18/_/_	13,7V18A	274	X		X
ZAT 27,4/10/_/_	27,4V10A	274	X		X
ZAT 54,8/5/_/_	54,8V5A	274	X		X

Anwendungsbeispiele:

- Battery back-up systems
- Temperature compensated charging
- Low voltage disconnecting unit

- Special features with external control:
- Boost charging
 - Battery test possibility
 - Shut down by external 4-15V voltage
 - Controllable output voltage

Parallel connection with output series diode and module fail alarm

Series connection ± Outputs

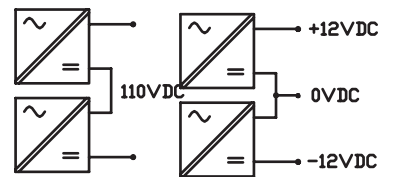
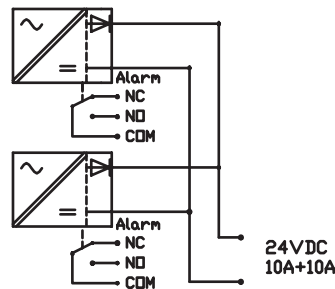
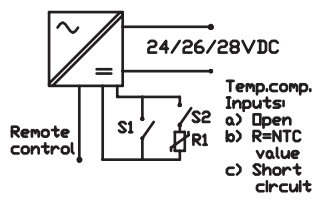
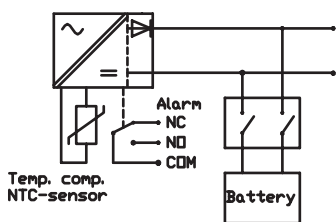

PIN Configuration 60W Models:

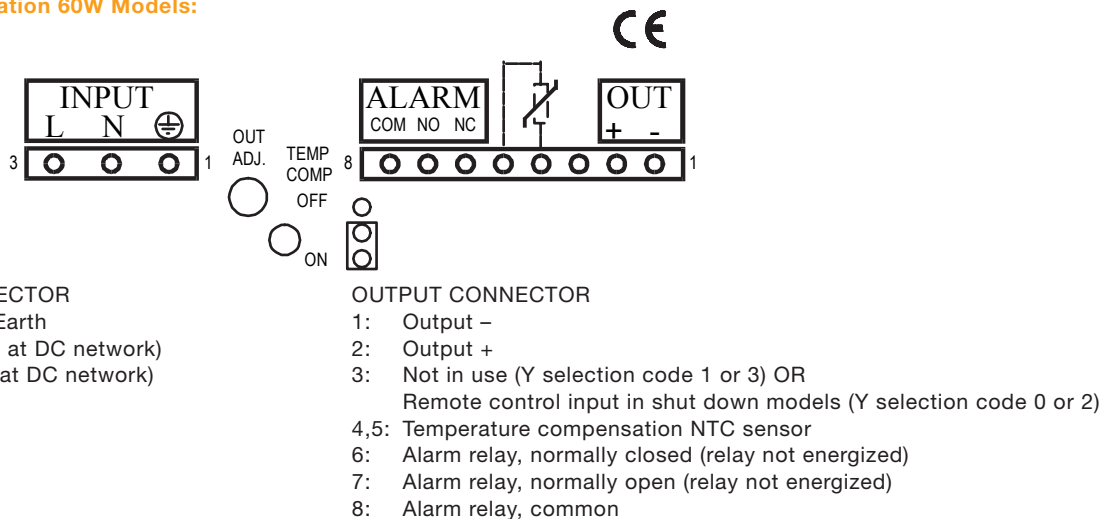

Use 60/70 or 75°C copper (CU) wire only. The recommended terminal tightening torque is 0.5Nm.

PIN Configuration 125W Models:

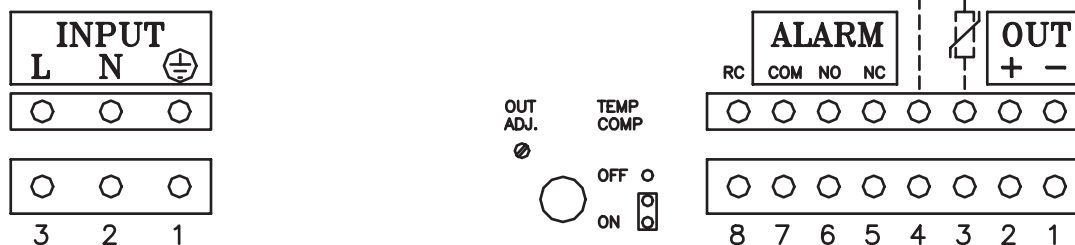

Use 60/70 or 75°C copper (CU) wire only. The recommended terminal tightening torque is 0.5Nm.

PIN Configuration 250W Models:

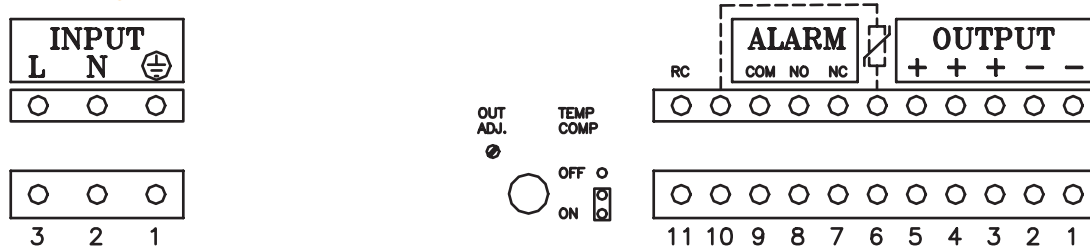

Use 60/70 or 75°C copper (CU) wire only. The recommended terminal tightening torque is 0.5Nm.

115/230V INPUT VOLTAGE SELECTION

125/250W models:

The unit is factory set to operate with a 230V nominal input voltage. The nominal input voltage can be selected via the internal 115/230 voltage selector on the PCB. Access to the selector is through the ventilation holes of the unit cover. **Always disconnect power before selecting.**

60W models:

The unit is wide input type and will work without modification from 90VAC to 264VAC.

USING UNIT WITH DC INPUT

60W units can be operated also by DC input voltage. See voltage range from specification and connection from pin configuration.

OUTPUT VOLTAGE ADJUSTMENT

The output voltage of the module can be adjusted with the multi-turn potentiometer located on the front panel. All models can be used either as a power supply or a charger by correct adjustment.

125W and 250W models: Maximum output current is available within the full voltage adjustment range.

60W models: Maximum output power is available within the full voltage adjustment range

ALARM RELAY

The potential free alarm output indicates if the output of the unit is healthy. Alarm relay contacts, both normally open and normally closed, are presented on the unit connector. If the output is healthy, the NO and COM pins are short circuited. If the unit fails the relay contacts will changeover and NC and COM pins will be short circuited. Word "normal" in relay pins means that mode when relay is not energized.

SERIES / PARALLEL CONNECTION

Reserve 2cm space on both sides for proper cooling.

Parallel operation: Do not chain the outputs, rated current 12A / pin. Recommended cable size: 2.5mm², length > 0.5m for optimum load sharing.

Series operation: Up to 500V total voltage.

TEMPERATURE COMPENSATION

Temperature compensated charging provides the optimum float charge voltage when batteries are being used. To utilize this feature it is necessary to install a NTC sensor across the temperature compensation pins on the output connector. It is also necessary to set the jumper on the front panel to ON position. The output voltage should be adjusted when the jumper is in the OFF position. This will simulate room temperature and ensure accuracy.

The recommended sensor type is a 2.2k ohm NTC resistor, e.g. Epcos B57164-K222-K. The sensor should be installed local to the batteries. The sensor is galvanically connected to the + output. Temperature compensation sensor is included in charger models (x =7, 8 or 9) delivery

LED

A green LED indicates that the output of the module is healthy.

OUTPUT OVERCURRENT PROTECTION

Automatic, self-resetting electronic current limiting is included and the output is short circuit proof.

OUTPUT OVER VOLTAGE PROTECTION (OPTION)

Output of the unit will shut down if the output voltage rises above protection level. (16Volts/12V models, 31Volts/24V models and 58 Volts/48V models). Protection must be manually resetted by disconnecting the AC main voltage.

OUTPUT VOLTAGE REMOTE SHUT DOWN AND BATTERY TEST OPTIONAL MODELS

Output of the unit will shut down, when a +4...15VDC signal is applied to the remote control input (RC) with reference to negative output.

In battery test models output voltage drops 15-25% , when a +4...15VDC signal is applied to the RC pins as above.

The output voltage will return to the original level, when +4...15VDC signal is removed from RC pins.

INTERNAL OUTPUT SERIES DIODE (OPTION)

The internal diode is placed in series with the positive output. The benefits of having the diode fitted are:

- Improved redundancy if the modules are connected in parallel (not for 60W models)
- Power OK signal and LED work independently regardless battery or parallel connections
- The parallel connected modules can be Hot Plug replaced without the system output power interruption
- The reverse current bleed is low if a battery is connected to the output of the charger

The disadvantages of having the diode fitted are lower efficiency, deration to the output voltage regulation and load sharing.

Note: The output series diode does not protect against reverse polarity connection of the battery.

WARNING!

Dangerous voltages, capable of causing death, are present in this equipment. Do not remove the cover. No operator serviceable parts inside. Refer servicing to qualified service personnel.